

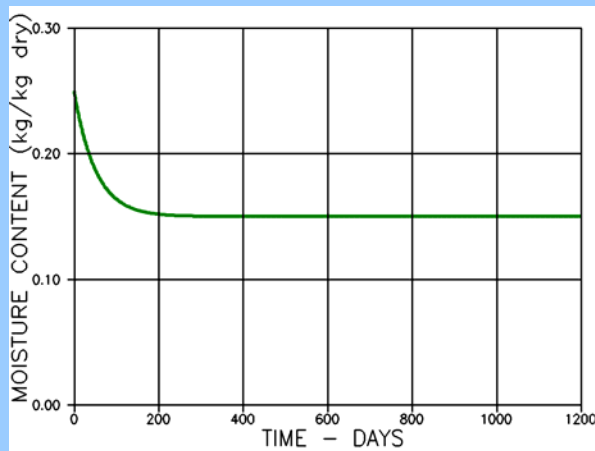

Power-Law creep as related to adapted Burgers creep representations and incremental analysis

Lauge Fuglsang Nielsen



Drying of wood from $u(0) = 0.25$ to $u(\infty) = 0.15$.

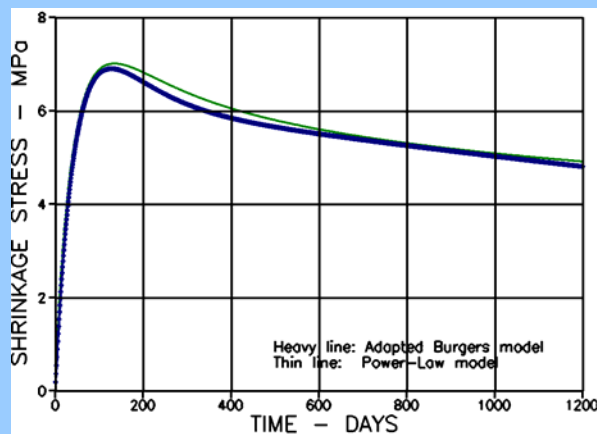

Stress due to drying of wood as described above. Predictions are based on the Power-Law model, and on the adapted Burgers model respectively.

Power-Law creep as related to adapted Burgers creep representations *and incremental analysis*

Lauge Fuglsang Nielsen

Department of Civil Engineering
Technical University of Denmark

Table of contents

| | |
|--|----|
| TABLE OF CONTENTS | 2 |
| Abstract | 3 |
| 1. POWER-LAW CREEP | 3 |
| 2. BURGERS CREEP FUNCTION..... | 4 |
| 3. GENERAL CREEP DESCRIPTION..... | 5 |
| 4. STRESS-STRAIN ANALYSIS | 7 |
| Incremental analysis..... | 7 |
| 5. SIMULATION OF POWER-LAW MODEL BY BURGERS MODEL..... | 8 |
| Adapted Burgers model..... | 9 |
| 6. APPLICATIONS | 10 |
| Example 1: Strain caused by step varying load..... | 10 |
| Example 2: Stress in wood caused by drying..... | 11 |
| Example 3: Prestressed wood (Composite)..... | 13 |
| Example 4: Creep of reinforced wood | 15 |
| Example 5: Curiosum: Maxwell material | 16 |
| 7. CONCLUSION AND FINAL REMARKS | 16 |
| ACKNOWLEDGEMENT | 17 |
| Notations | 18 |
| Appendix A: On adapted Burgers models..... | 18 |
| Appendix B: On the elastic-viscoelastic analogy..... | 19 |
| LITERATURE | 19 |

Power-Law creep as related to adapted Burgers creep representations and incremental analysis

Lauge Fuglsang Nielsen

Department of Civil Engineering
Technical University of Denmark

Abstract

A number of viscoelastic materials exhibit so-called Power-Law creep. Various analytical methods exist by which this expression can be used in accurate analysis of *materials behavior*. In modern *structural analysis by FEM techniques*, however, application of the Power-Law creep expression is somewhat inefficient. It cannot, in a simple way, be formulated in an incremental way such that the 'next step' in an analysis can be predicted by the immediate stress-strain situation. Very much time is used for large integrations.

The Power-Law creep expression is presented in this paper together with an easy method to replace it with an approximate creep model (adapted Burgers model), which is applicable in incremental analysis of structures. The method applies for any so-called creep power $0 < b < 1$, (numerically $0.000000001 \leq b \leq 0.999999999$).

The errors turning up in stress-strain analysis when going from a Power-Law model to an adapted Burgers model is discussed at the end of the paper: Used properly the conversion of rheological models will not cause significant errors in an overall analysis.

Deliberately the method presented avoids establishing a Burgers model directly from experimental creep data because such a procedure will provoke errors, which are irreversible. This feature is also discussed at the end of the paper.

It is assumed that the reader is familiar with elementary rheology as presented in (e.g. 1,2): Definition of creep- and relaxation functions, rheological spectra, and elastic-viscoelastic analogies, for example. Notations used are listed at the end of the paper.

1. Power-law creep

The Power-Law creep model presented in Table 1 is the result of a complete analysis made in (3) of an expression, $c(t) = (1 + at^b)/E$ suggested by Clouser (4) with constants a and b , which is very often used successfully in the literature (e.g. 5) to fit experimental data from creep tests on a variety of building materials such as wood, polymers, and ceramic materials. Physically Clouser's expression is very unfortunate (one material constant " a " has the dimension of time raised to minus the other material constant " b ").

Re-formulated, however, as it is in Table 1 the expression becomes viscoelastically sound, characterizing the materials rheology by independent material properties, namely the dimensionless creep power, b , and the curing dependent relaxation time τ_p . Also shown in Table 1 is the Power-Law relaxation function, developed in (3). Examples of both creep and relaxation functions for Power-Law creeping materials are shown in Figures 1 and 2.

The Power-Law model is a very efficient tool in viscoelastic stress-strain analysis (2). A number of material problems for a number of different materials can be solved in one approach, by developing standard solutions ('master solutions') from which solutions for specific materials

at various ambient curing conditions can be picked, introducing specific material parameters, τ_p and b . For wood, for example, we may estimate creep parameters as suggested in Equation 1 reproduced from (3,6,7) for *constant levels of moisture content and temperature*.

| Power-Law model | |
|---|--|
| Creep function | Relaxation function |
| $c(t) = \frac{1}{E_p} \left(1 + \left(\frac{t}{\tau_p} \right)^b \right)$ | $r(t) = E_p \sum_{k=0}^{\infty} \frac{(-Z(t))^k}{\Gamma(1+kb)}$ <p>with $Z = \Gamma(1+b) \left(\frac{t}{\tau_p} \right)^b$</p> $r(t) \approx E_p \frac{1+Z}{1+2Z + \frac{b\pi}{\sin(b\pi)} \frac{Z^2}{\Gamma(1+b)}} \quad (b < 1/2) \quad \text{or} \quad r(t) \approx \frac{1}{c(t)} \quad (b < 1/3)$ |

Table 1. Power-Law creep- and relaxation functions. Reproduced from (3). The gamma function is denoted by $\Gamma(1+b) = \text{faculty } b!$. E_p and τ_p is Young's modulus and relaxation time respectively. b is creep power.

| | |
|--|-----|
| <p>Wood: Creep power $b \approx \begin{cases} 0.2 - 0.25 & \neq \text{grain} \\ 0.25 - 0.3 & \perp \text{grain} \end{cases}$</p> <p>Relaxation time $\tau_p = \tau_{15} * 10^{(15 - u)/10 + (20 - T)/15}$</p> <p>where $u(\%)$ is moisture content (kg / kg dry) and $T(^{\circ}\text{C})$ is temperature and</p> <p>$\tau_{15} \approx \begin{cases} 10^4 - 10^5 \text{ days} & \neq \text{grain} \\ 30 - 300 \text{ days} & \perp \text{grain} \end{cases}$ is relax-time at $u = 15\%$ and $T = 20^{\circ}\text{C}$</p> | (1) |
|--|-----|

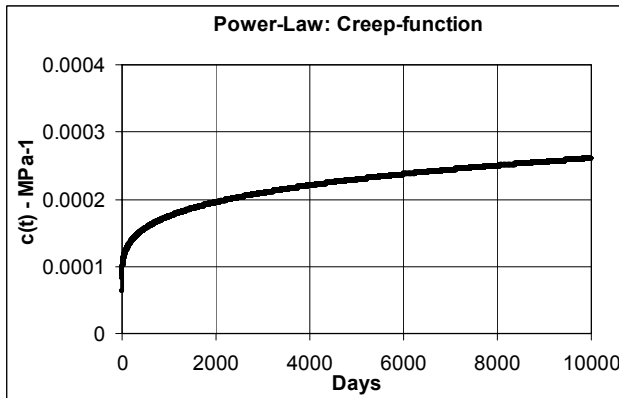

Figure 1. Power-Law creep: $E_p = 16000 \text{ MPa}$, $\tau_p = 100 \text{ days}$, $b = 0.25$.

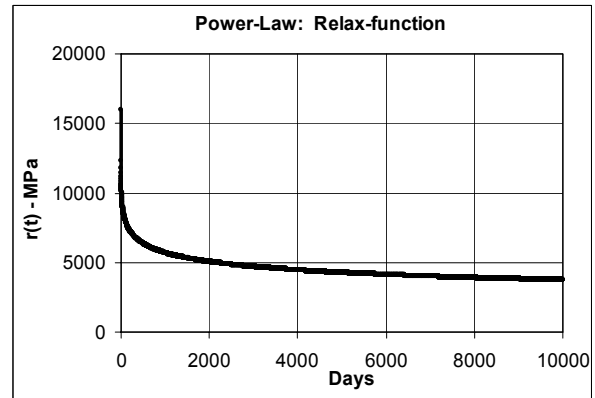

Figure 2. Power-Law relaxation: $E_p = 16000 \text{ MPa}$, $\tau_p = 100 \text{ days}$, $b = 0.25$.

Curiosum: Two special features apply to a Power-Law creep function: 1) It starts up at $t = 0$ with a vertical tangent – and 2) it ends at $t \rightarrow \infty$ with a horizontal tangent although its value approaches infinity. Correspondingly the relaxation function also starts up with a vertical tangent, and approaches 0 as $t \rightarrow \infty$.

2. Burgers creep function

The viscoelastic behavior of building materials, which do not follow a Power-Law creep description, can often be modeled by the so-called Burgers model illustrated in Figure 3. Creep- and relaxation functions for this model are presented in Table 2 reproduced from (2). More explicitly, the creep function is expressed by Equation 2, illustrated in Figure 4.

| Burgers model | |
|--|---|
| Creep function | Relaxation function |
| $c(t) = \frac{1}{E} \left(1 + \frac{t}{\tau} + \alpha \left[1 - \exp \left(-\frac{t}{\tau_K} \right) \right] \right)$ | $r(t) = \frac{E}{m_{B1} - m_{B2}} \left[(m_{B1} - 1) \exp \left(-m_{B1} \frac{t}{\tau_K} \right) - (m_{B2} - 1) \exp \left(-m_{B2} \frac{t}{\tau_K} \right) \right]$ |
| $\tau = \frac{\eta}{E} ; \tau_K = \frac{\eta_K}{E_K} ; \alpha = \frac{E}{E_K} ; m_{B1} = \frac{1}{2} \left(1 + \alpha + \frac{\tau_K}{\tau} \pm \sqrt{\left(1 + \alpha + \frac{\tau_K}{\tau} \right)^2 - 4 \frac{\tau_K}{\tau}} \right)$ | |

Table 2. Burgers creep- and relaxation function. Reproduced from (2).

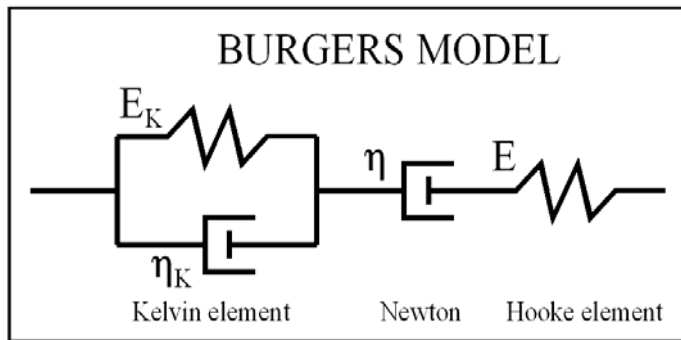

Figure 3. Burgers model.

$$c(t) = \frac{1}{E} + \frac{t}{\eta} + \frac{1}{E_K} \left(1 - \exp \left(-\frac{t * E_K}{\eta_K} \right) \right) \quad \text{Burgers creep function} \quad (2)$$



Figure 4. Burgers creep function: $E = 16000 \text{ MPa}$, $\eta = 6.4 * 10^6 \text{ MPa*day}$, $E_K = 16000 \text{ MPa}$, $\eta_K = 4.8 * 10^5 \text{ MPa*day}$.

3. General creep description

A description of creep functions for viscoelastic material in general, such as e.g. Power-Law and Burgers materials, is based on the Kelvin chain mechanical model shown in Figure 5. The creep expressions associated are presented in Equation 3, where $L(\theta)$ is a so-called retardation spectrum quantifying the rheological parameters for an infinite number of so-called Kelvin elements with relaxation times (θ) as defined in Figure 5.

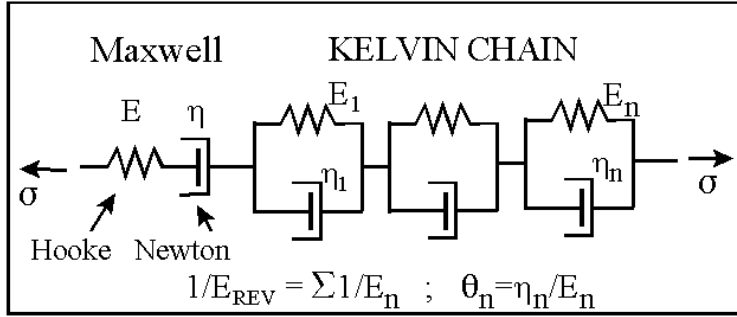

Figure 5. Generalized mechanical model for a viscoelastic material. η and $\theta = \eta/E$ denote viscosities and relaxation times respectively.

$$c(t) = \begin{cases} \left(\frac{1}{E} + \frac{t}{\eta} + \sum_{n=1}^N \frac{1}{E_n} \left(1 - \exp\left(-\frac{t}{\theta_n}\right) \right) \right) & \text{Finite number (N) of Kelvin elements} \\ \left(\frac{1}{E} + \frac{t}{\eta} + \int_0^{\infty} \frac{L(\theta)}{\theta} \left(1 - \exp\left(-\frac{t}{\theta}\right) \right) d\theta \right) & \text{Infinite number of Kelvin elements} \end{cases} \quad (3)$$

The retardation spectrum presented in Equation 4 has been developed by the author in (3) for a Power-Law material. An example of determining creep functions from retardation spectra is presented just below.

For Power-Law Creep: Young's modulus $E = E_p$, viscosity $\eta = \infty$ and

$$L(\theta) = \frac{Z(\theta) \sin(b\pi)}{\pi E_p} \quad \text{with } Z(\theta) = \Gamma(1+b) \left(\frac{\theta}{\tau_p} \right)^b \quad \text{Retardation spectrum} \quad (4)$$

Example: For relaxation times $\theta \leq 10^6$ days the viscoelasticity of a material is given by the retardation spectrum, $L(\theta)$, presented in Equation 4 with $E_p = 16000$ MPa, $b = 0.25$, and $\tau_p = 100$ days. For $\theta > 10^6$ days, however, $L(\theta) \equiv 0$ applies.

The question is, *which creep function is associated with this retardation spectrum*. We only consider materials with a locked free viscosity, meaning $\eta = \infty$ (in Figure 5 and Equation 3).

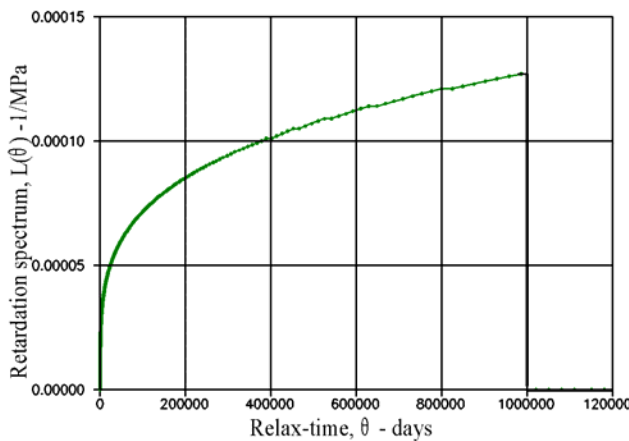

Figure 6. Retardation spectrum as defined in the main text.

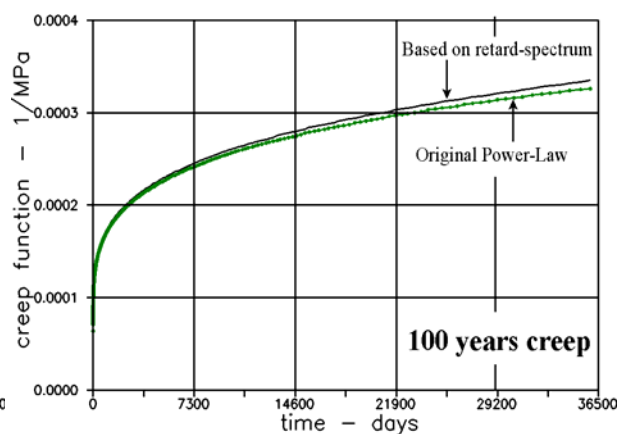

Figure 7. Creep function associated with the retardation spectrum illustrated in Figure 6.

Equation 3 gives the answer, namely the creep function presented in Figure 7. A Power-Law creep function (with the above indicated E_p, b, τ_p) is also shown in this figure. It is obvious that the creep function determined from the retardation spectrum relates closely to this Power-Law creep function. (With no truncation at $\theta = 10^6$ days of the spectrum in Equation 4, the two solutions will coincide completely).

Remark: Obviously, the viscosity of Power-Law materials can be described by an infinite number of Kelvin elements in Figure 5. For a Burgers material only one such element is required.

4. Stress-strain analysis

An analysis of viscoelastic materials is very often made by the classical stress-strain relation shown in Equation 5. For any stress change, integration is required all the way from $t = 0$ to time of change.

$$\varepsilon(t) = \begin{cases} \int_0^t c(t-\rho) \frac{d\sigma}{d\rho} d\rho & \text{(continuous stress variation)} \\ \Delta\sigma_1 c(t-t_1) + \Delta\sigma_2 c(t-t_2) + \Delta\sigma_3 c(t-t_3) + \dots & \text{(step-varying stress)} \end{cases} \quad (5)$$

Incremental analysis

In structural analysis with FEM such a procedure is very time consuming. The so-called incremental formulation of the stress-strain relation outlined in Equation 6 is to prefer because the ‘next step’ of analysis can be predicted by the immediate stress-strain situation without involving numerous integrations back from $t = 0$. This process is replaced by the more convenient procedure of continuously following the strain (ε_K) in the Kelvin elements.

$$\frac{d\varepsilon}{dt} = \frac{d\varepsilon_H}{dt} + \frac{d\varepsilon_N}{dt} + \frac{d\varepsilon_K}{dt} \quad \text{Incremental formulation of stress-strain relation}$$

with

$$\frac{d\varepsilon_H}{dt} = \frac{1}{E} \frac{d\sigma}{dt} \quad \text{(Hooke)}$$

$$\frac{d\varepsilon_N}{dt} = \frac{\sigma}{\eta} \quad \text{(Newton)}$$

$$\frac{d\varepsilon_K}{dt} = \frac{\sigma - E_K \varepsilon_K}{\eta_K} \quad \text{(Kelvin) (* for each Kelvin in a chain)}$$

It is easily checked that identical solutions are obtained using Equations 5 and 6. Simple examples will illustrate this feature: A Burgers material is subjected to a constant load (1 MPa) up to 150 days where it is completely unloaded. The strains produced analytically and incrementally respectively are shown in Figures 6. For the same Burgers material the relaxation functions shown in Figure 7 are determined by Table 2 and Equation 7 respectively. The latter expression is developed by the author in (8) on the basis of Equation 6.

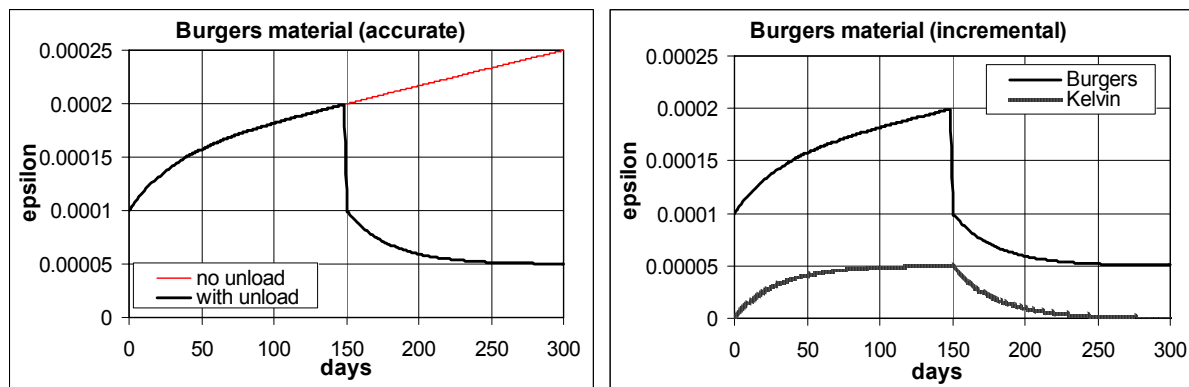

Figure 6. Creep function for Burgers material, calculated analytically and incrementally. $E = 10000$ MPa, $\eta = 3e6$ MPa*day, $E_K = 20000$ MPa, $\eta_K = 6e5$ MPa*day

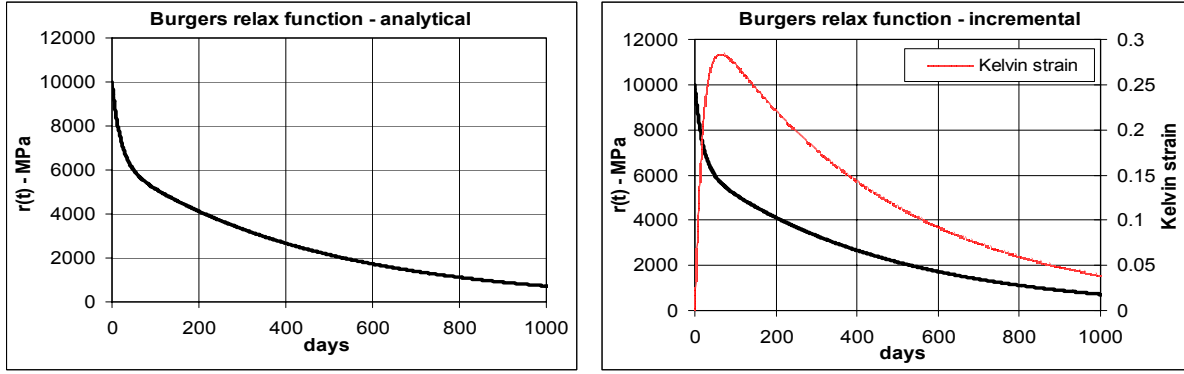

Figure 7. Relaxation function for Burgers material, calculated analytically and incrementally. $E = 10000 \text{ MPa}$, $\eta = 3e6 \text{ MPa}\cdot\text{day}$, $E_K = 20000 \text{ MPa}$, $\eta_K = 6e5 \text{ MPa}\cdot\text{day}$

$$\frac{dr(t)}{dt} = E \left[-r(t) \left(\frac{1}{\eta} + \frac{1}{\eta_K} \right) + \frac{E_K \epsilon_K}{\eta_K} \right] \quad \text{with} \quad \frac{d\epsilon_K}{dt} = \frac{r(t) - E_K \epsilon_K}{\eta_K} \quad (7)$$

Remark: It is emphasized that re-writing the Power-Law in an incremental formulation is not impossible. It is, however, a very complex task involving an infinite number of Kelvin elements to be handled as indicated in Equation 6 with complex combinations of retardation spectra. The gain in calculation time relative to classical analytical procedures, represented by Equation 5, is easily lost in this process.

However, as subsequently explained, a method can be established by which we may simulate Power-Law creep approximately by Burgers creep – meaning that a simple incremental analysis can be used with only one Kelvin element.

5. Simulation of Power-Law model by Burgers model

In this section we will simplify matters 1) by utilizing the observation made in Section 1 that Power-Law creep starts up at $t = 0$ with a vertical tangent, and 2) by reducing the number of Kelvin elements to only one. In this way we get a Burgers model – with an extra, ‘invisible’, Kelvin element, which develops extremely fast. A reduced stiffness, E , (‘static stiffness’) is a consequence of such a simplification.

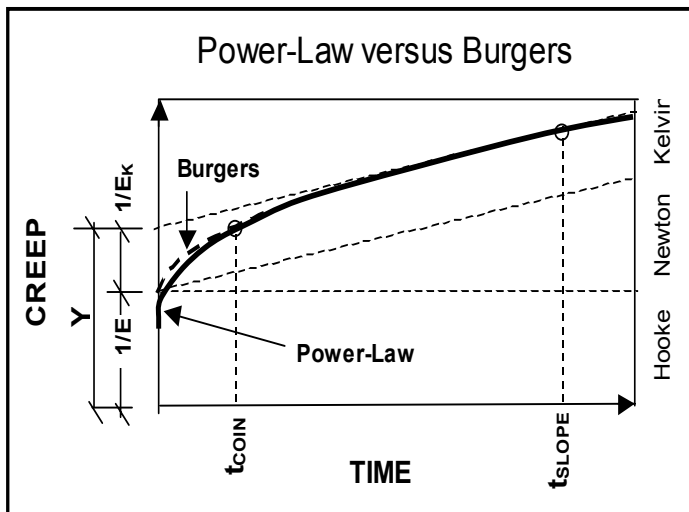

Figure 8. Principles of modifying the Burgers model to approximate a Power-Law model. Details are presented in Table 4 and in Appendix A at the end of this paper.

Adapted Burgers model

A Burgers model is adapted to approximate the Power-Law creep expression as follows (see also Figure 8 and Appendix A at the end of the paper):

- The vertical Power-Law tangent at $t = 0$, previously referred to, is considered by a reduced (static) Young's modulus E . Originally the idea of 'hiding' a rapid Kelvin element in a reduced Young's modulus was suggested in the authors work (9) on creep of concrete.
- The Power-Law slope at t_{SLOPE} determines the viscosity η .
- The Kelvin Young's modulus E_K is determined as indicated in Figure 8.
- The Kelvin viscosity η_K is determined from assuming Power-Law creep and Burgers creep to coincide at t_{COIN} .

The results of this adaption procedure are compiled in Table 4. The 'Period of analysis' (T) and the 'Calibration parameters' (t_{SLOPE} , t_{COIN} , and Δ) introduced in the third row of the table are results of a number of evaluation tests as explained in Section 6.

| POWER-LAW | |
|--------------------------------|---|
| Creep parameters | E_P, b, τ_P |
| Period of analysis | T |
| Calibration parameters | $t_{\text{SLOPE}} \approx 0.75 * T, t_{\text{COIN}} \approx T/10, \Delta \approx T * (1 - b^2) / 100$ |
| BURGERS | |
| | |
| E (Young's modulus) | $\frac{E_P}{1 + \left(\frac{\Delta}{\tau_P}\right)^b}$ |
| η (Viscosity) | $\frac{E_P t_{\text{SLOPE}}}{b} \left(\frac{t_{\text{SLOPE}}}{\tau_P}\right)^{-b}$ |
| E_K (Kelvin Young's modulus) | $\frac{1}{\frac{1}{E_P} \left(1 + (1 - b) \left(\frac{t_{\text{SLOPE}}}{\tau_P}\right)^b\right) - \frac{1}{E}}$ |
| η_K (Kelvin viscosity) | $\frac{-t_{\text{COIN}} * E_K}{\log_e \left(1 - E_K \left(\frac{1}{E_P} \left(1 + \left(\frac{t_{\text{COIN}}}{\tau_P}\right)^b\right) - \frac{1}{E} - \frac{t_{\text{COIN}}}{\eta}\right)\right)}$ |

Table 4. Determination of rheological parameters for the adapted Burgers model.

Remarks: It is noticed from Table 4 that the calibration parameter Δ determines the effective Young's modulus (or reduced stiffness) previously mentioned, which simultaneously consi-

ders real stiffness of the Power-Law material together with the stiffness of an extremely fast-working Kelvin element.

The ‘period of analysis’ (T) is the period of time where an adapted Burgers model can replace a Power-Law model in stress-strain analysis. Some errors (after stress jumps) will turn up in this time period. They will, however, be controllable – and very often of no significance in an *overall analysis* of structures. Examples of this statement are shown in the following section.

6. Applications

Four examples are considered in this section. They are thought to simulate 1) a structural analysis, 2) a materials analysis, and 3) + 4) a composite analysis respectively. Further, an example 5) demonstrates the power of the method presented in this paper also to apply when a creep power of $b = 1$ is used, meaning that the Power-Law material considered has degenerated to a so-called Maxwell material.

The evaluations made go directly between results obtained by an exact Power-Law analysis (Equation 5 with Table 1) and results obtained by an exact Burgers analysis (Equation 5 with Table 2). This evaluation applies equally well, comparing a Power-Law analysis with an incremental Burgers analysis. It was shown in Section 4 that an incremental analysis and a classical analysis (by Equation 5) of a Burgers material give identical results.

Example 1: Strain caused by step varying load

The specific problem considered in this example is the determination of the strain history in a Power-Law material subjected to a step-varying load – and to evaluate errors turning up as the result of using an adapted Burgers stress-strain relation as the basis of analysis.

The Power-Law material considered in this example is described in Table 5 together with parameters determined by Table 4 for the adapted Burgers material. The respective creep- and relaxation functions are presented in Figure 9 as predicted by Tables 1 and 2.

The load history previously outlined is illustrated in Figure 10 together with the strain history associated, calculated as previously indicated in Equation 5.

| Power-Law material considered |
|---|
| $E_p = 16000 \text{ MPa}$, $\tau_p = 10000 \text{ days}$, $b = 0.2$. (\neq to grain) |
| Duration of analysis: $T = 10000 \text{ days}$ (30 years) |
| Adapted Burgers model |
| $E = 11470 \text{ MPa}$, $\eta = 6.36 \text{ e}8 \text{ MPa*day}$, $E_K = 44393 \text{ MPa}$, and $\eta_K = 5.04 \text{ e}7 \text{ MPa*day}$ |

Table 5. Example 1: Power-Law creep parameters and associated parameters for the adapted Burgers.

Discussion: From Figure 10 is observed that there can hardly be observed any difference between results of the two prediction methods applied. This statement is, of course, made from a practical point of view, which considers the overall analysis (here 30 years). Apparently the inherent ‘errors’ of the adapted Burgers method fade out as time proceeds to long times (within the time, T, decided for the duration of analysis) – meaning that these ‘errors’, revealing themselves most obviously in plain creep- and relaxation predictions (see Figure 9), will not influence significantly a stress-strain analysis in practice. The topic of errors is further discussed in Section 7.

It is emphasized that the consequences of the errors just discussed are of exactly the same kind as those introduced from uncertainties involved in the experimental determination of

creep functions – especially the determination of Young’s moduli. Dynamic or static values? How does these quantities depend on rate of testing? Discussions on this feature have been presented in (3).

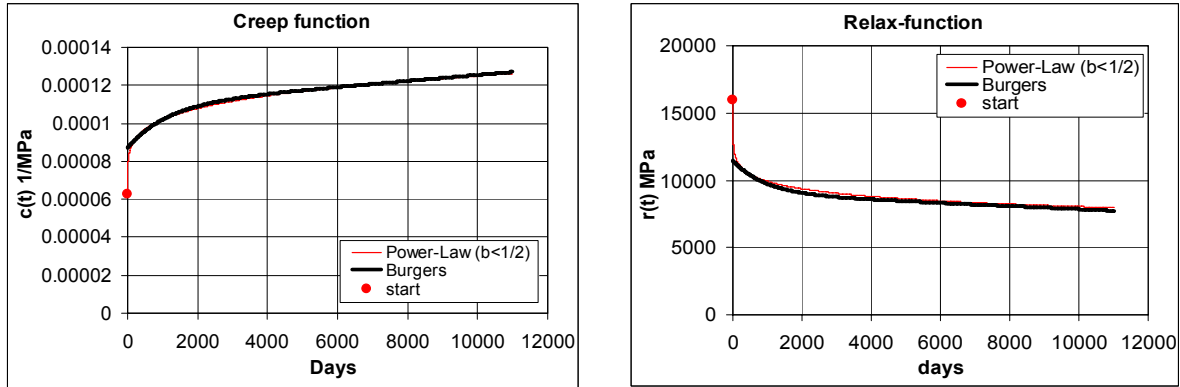

Figure 9. A 30 years analysis of the creep- and relaxation functions for the Power-Law material and the adapted Burgers material considered in Table 5.

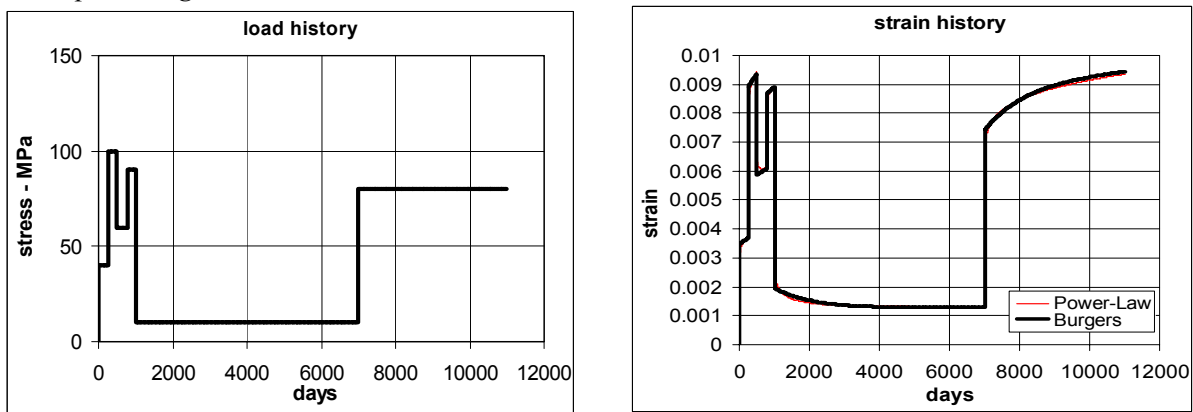

Figure 10. Example 1: A 30 years stress-strain analysis of the Power-Law material considered. Calculations made by both Power-Law and the adapted Burgers model.

Auxiliary figure for the analysis of shrinkage stress in a wood specimen of fixed length

Moisture history (kg/kg dry) is: $u(t) = u(0) - \Delta * [1 - \exp(-t/\alpha)]$
 where $\Delta = u(0) - u(\infty)$ is max drying and α is relax-time of drying
 s is shrinkage coefficient [strain/unit moisture change]

$$\epsilon_{SH} = s * [u(0) - u(t)]$$

Fixed length

Elastic stress: $\sigma = E * \epsilon_{SH}$

Viscoelastic stress: $\sigma = s \int_0^t r(t - \theta) \frac{d[u(0) - u(\theta)]}{d(\theta)} d\theta$

Figure 11. Auxiliary figure for the analysis of stress in wood during drying.

Example 2: Stress in wood caused by drying

In this example we will check the ability of an adapted Burgers model to work as the basis in an analysis of stress caused by drying of a wood specimen of fixed length.

The ‘true’ viscoelastic behavior of the wood considered is assumed to follow the Power-Law model described in the Table 6 which also show the adapted Burgers parameters as they apply for a duration of analysis, $T = 1200$ days.

The basic procedures to follow in the present stress-strain analysis are presented in Figure 11. The moisture (drying) history considered is presented in Figure 12. A shrinkage coefficient of $s = 0.2$ is assumed in both Power-Law and Burgers analysis. In details the analysis is straight forward as explained in previous parts of the paper. No further comments will be given. The results obtained, and graphically presented in Figure 13, speak for themselves.

| Power-Law material considered (Wood) | |
|--|----------------|
| $E_p = 800$ MPa, $\tau_p = 50$ days, $b = 0.25$, (shrinkage: $s = 0.2$ per kg/kg dry) | Perp. to grain |
| Duration of analysis: $T = 1200$ days | |
| Adapted Burgers model | |
| $E = 473$ MPa, $\eta = 1.4 \text{ e}6$ MPa*day, $E_K = 935$ MPa, and $\eta_K = 1.3 \text{ e}5$ MPa*day | |

Table 6. Example 2: Power-Law creep parameters and associated parameters for the adapted Burgers model.

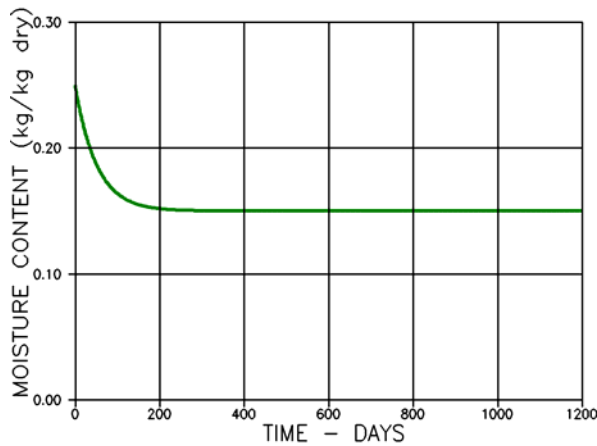

Figure 12. Example 2: Drying from $u(0) = 0.25$ to $u(\infty) = 0.15$ with a relax-time of drying, $\alpha = 50$ days.

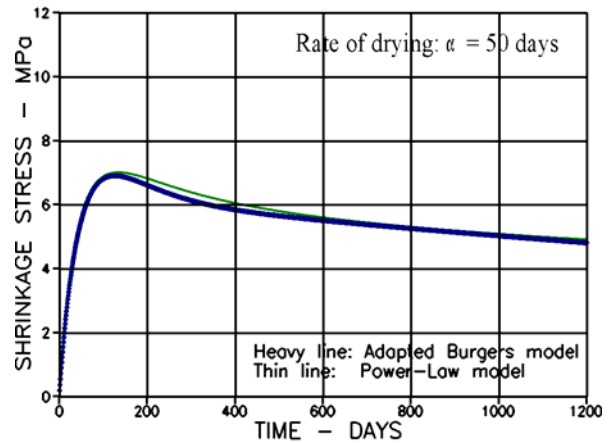

Figure 13. Example 2: Stress due to drying as described in Figures 11 and 12. Predictions are based on the Power-Law model, and on the adapted Burgers model respectively. For the latter model a duration of analysis, $T = 1200$ days is assumed.

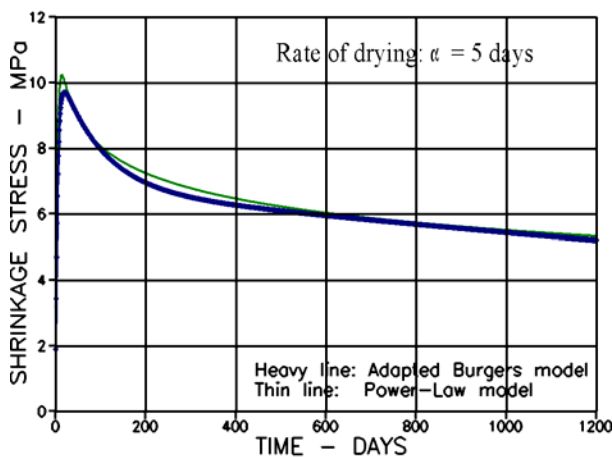

Figure 14. Example 2: Shrinkage stress developed in the wood specimen considered if rate of drying is increased corresponding to $\alpha = 5$ days.

Remarks: The viscoelastic stress results presented are obtained from the elastic solution (in Figure 11) using the so-called elastic-viscoelastic analogy explained in (e.g. 2); see also Appendix B at the end of this paper.

For the sake of curiosity, a stress analysis has also been made for a more rapid drying ($\alpha = 5$ days) as was assumed in Figures 12 and 13. The result is shown in Figure 14. It is obvious that accelerating a drying process increases the risk of damaging the wood being processed.

Example 3: Prestressed wood (Composite)

In this example we will check the ability of an adapted Burgers model to work in an analysis of a wood composite: More specifically we consider a wood specimen, see Figure 15, subjected to prestress.

The ‘true’ viscoelastic behavior of the wood considered is assumed to follow the Power-Law model specified in Table 7 which also show the adapted Burgers parameters as they apply for a duration of analysis of $T = 1000$ days. Prestress details are also presented in Table 7.

The basic procedure to follow in the stress-strain analysis is outlined in Table 8. The viscoelastic stress result presented is obtained from the elastic solution using the so-called E_{EFF} -method (effective Young’s modulus method) explained in (2) and in Appendix B at the end of this paper. This method applies very accurately for creep powers $b < 1/3$ (2). Some results obtained by Table 8 are presented in Figures 16 and 17. As usual the Burgers solutions are obtained by switch of creep functions.

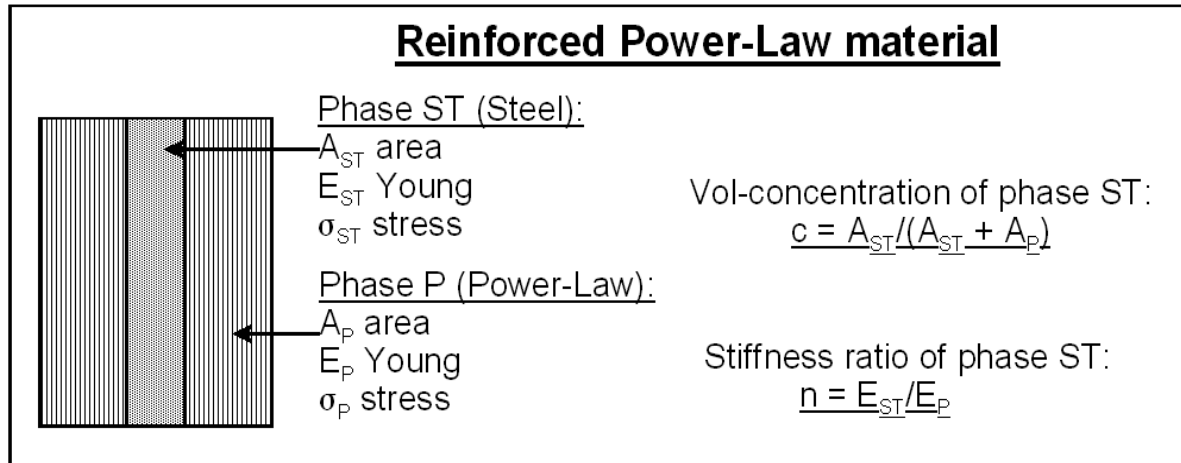

Figure 15. Example 3: Auxiliary figure for the prestress analysis of wood.

| Power-Law material (Wood) |
|---|
| $E_P = 1000$ MPa, $\tau_P = 50$ days, $b = 0.25$ (perpendicular to grain) |
| Duration of analysis: $T = 1000$ days |
| Adapted Burgers model |
| $E = 603$ MPa, $\eta = 1.52e6$ MPa*day, $E_K = 1223$ MPa, and $\eta_K = 1.45e5$ MPa*day |
| Steel |
| $E_P = 200000$ MPa, $c = 1$ ‰ (0.001), $A_{ST} = 3$ cm ² |
| Cable force before bonding: $F^0 = 50$ kN ($\Rightarrow \sigma_{ST}^0 = 167$ MPa) |

Table 7. Example3: Power-Law creep parameters and associated parameters for the adapted Burgers material. Prestress details are also presented

Prestressing: Steel stress is σ_{ST}^0 just before bonding at $t=0$

$$\left. \begin{array}{l}
 c\sigma_{ST} + (1-c)\sigma_P = 0 \\
 \varepsilon_{ST} = \varepsilon_P = \varepsilon \\
 \varepsilon_{ST} = \frac{\sigma_{ST} - \sigma_{ST}^0}{E_{ST}}; \quad \varepsilon_P = \frac{\sigma_P}{E_P}
 \end{array} \right\} \begin{array}{l}
 \text{Equilibrium} \\
 \text{Compability} \\
 \text{Physical conditions}
 \end{array} \Rightarrow \left\{ \begin{array}{l}
 \text{Elastic solution:} \\
 \sigma_{ST} = \frac{(1-c)\sigma_{ST}^0}{1+c(n-1)}
 \end{array} \right.$$

$$\Rightarrow \left\{ \begin{array}{l}
 \text{Approximate viscoelastic solution:} \\
 \sigma(t)_{ST} \approx \frac{(1-c)\sigma_{ST}^0}{1+c(n_{EFF}-1)} = \frac{1+c(n-1)}{1+c(n_{EFF}-1)} \sigma(0)_{ST} \text{ where } \sigma(0)_{ST} = \sigma(t=0)_{ST} = \frac{(1-c)\sigma_{ST}^0}{1+c(n-1)} \\
 \text{Effective stiffness ratio is } n_{EFF} = E_{ST}c_P(t) \text{ where } c_P(t) \text{ is Power-Law creep function} \\
 \text{Composite strain equals } \varepsilon_{ST}
 \end{array} \right.$$

Table 8. Example3: Outlines of an analysis of wood subjected to prestress.

Discussion: Similar comments can be made to the success of predicting prestress behavior by adapted Burgers models, as for predicting strain under variable stress in Example 1. The inherent ‘errors’ of the Burgers model do not significantly influence the overall results of such an analysis.

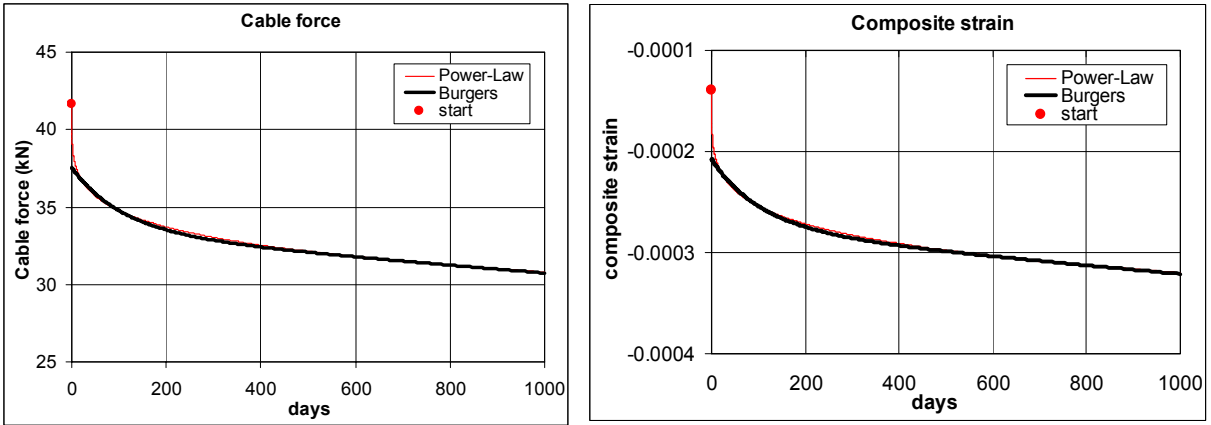

Figure 16. Example 3: Cable force and strain in a prestressed wood specimen.

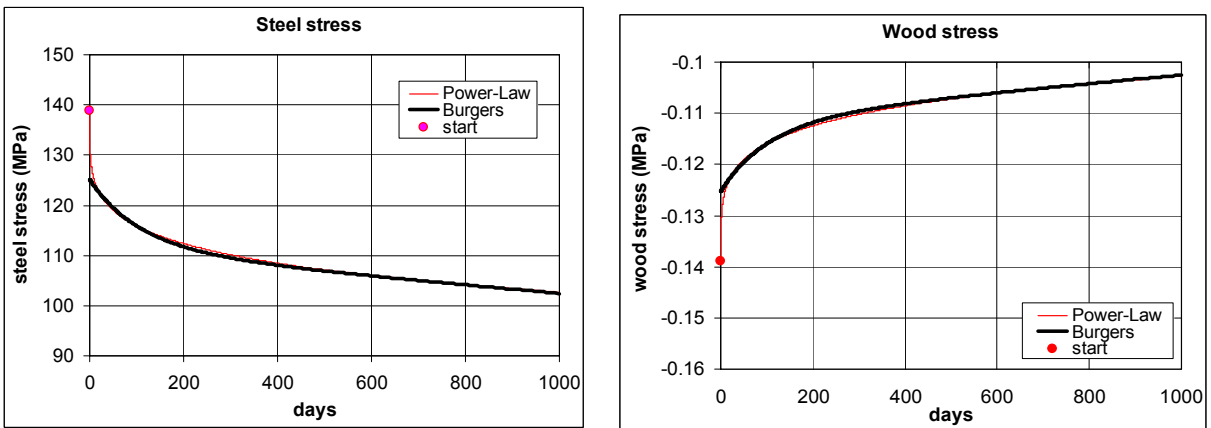

Figure 17. Example 3: Stresses developed in a prestressed wood specimen.

Example 4: Creep of reinforced wood

A wood specimen is reinforced parallel to grain. Which creep functions apply parallel and perpendicular to grain respectively? Layout and stiffness formulas from (10) are shown in Figure 18. Materials data are presented in Table 9. Creep is determined by the simple e-v-analogy outlined in Appendix B at the end of the paper. The results are presented in Figures 19 and 20.

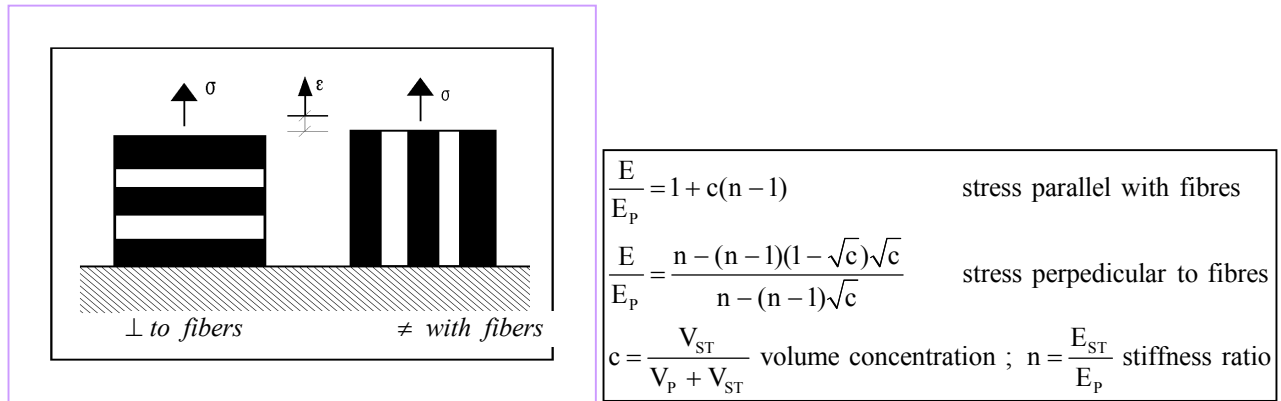

Figure 18. Wood reinforced perpendicular to, and parallel with fibres

| Power-Law material (Wood) |
|--|
| $E_p = 1000 \text{ MPa}$, $\tau_p = 50 \text{ days}$, $b = 0.25$ (perpendicular to grain) |
| $E_p = 16000 \text{ MPa}$, $\tau_p = 10000 \text{ days}$, $b = 0.2$ (parallel with grain) |
| Duration of analysis: $T = 1000 \text{ days}$ |
| Adapted Burgers model |
| $E = 603 \text{ MPa}$, $\eta = 1.52e6 \text{ MPa*day}$, $E_K = 1223 \text{ MPa}$, and $\eta_K = 1.45e5 \text{ MPa*day}$ (perp. to gr.) |
| $E = 12809 \text{ MPa}$, $\eta = 1.01e8 \text{ MPa*day}$, $E_K = 70362 \text{ MPa}$, and $\eta_K = 8.0e6 \text{ MPa*day}$ (parallel to gr.) |
| Reinforcement (Steel) |
| $E_{ST} = 200000 \text{ MPa}$, $c = 20 \%$ (reinforcement) |

Table 9. Example4: Power-Law creep parameters and associated parameters for the adapted Burgers material.

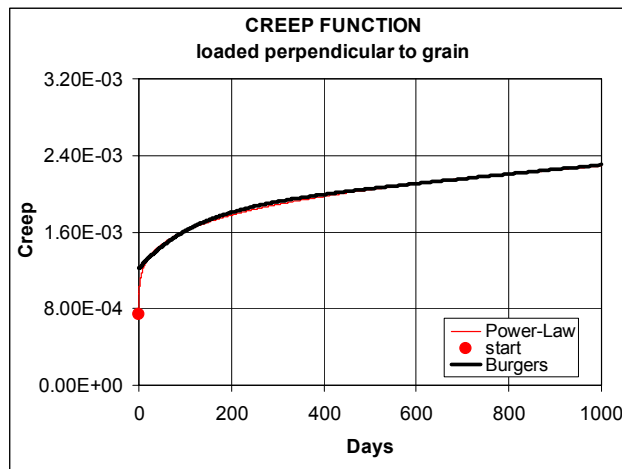

Figure 19. Creep function, perpendicular to grain of wood reinforced parallel to grain.

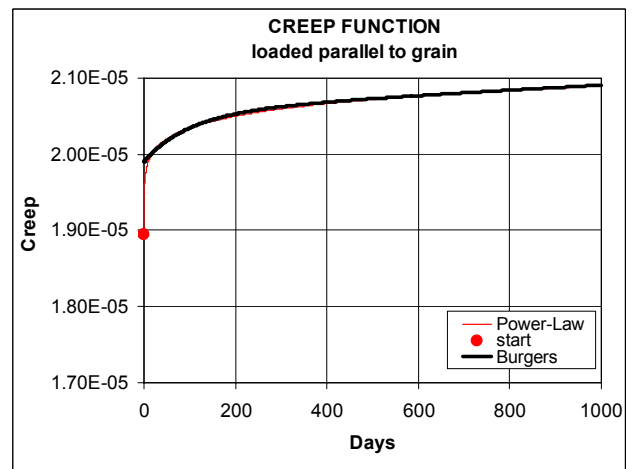

Figure 20. Creep function parallel to grain of wood reinforced parallel to grain.

Example 5: Curiosum: Maxwell material

Finally, as a curiosum we will demonstrate the applicability of the method presented also to describe the behavior of Maxwell materials. A Maxwell model is a Burgers model without the Kelvin element. It is also a Power-Law model with a creep power of $b = 1$. The accurate creep- and relax-functions presented in Equation 8 are from (e.g. 2)

$$\left\{ \begin{array}{l} \text{A Maxwell material can be described} \\ \text{as a Power-Law material with } b=1: \end{array} \right. \Rightarrow \left\{ \begin{array}{l} c(t) = \frac{1}{E_p} \left(1 + \frac{t}{\tau_p} \right) \quad \text{creep function} \\ r(t) = E_p \exp\left(-\frac{t}{\tau_p}\right) \quad \text{relaxation function} \end{array} \right. \quad (8)$$

Figure 21 confirms the ability of the method presented in this paper also to apply when going from a Maxwell model described as a Power-Law model with $b = 1$ to a Maxwell models traditionally described.

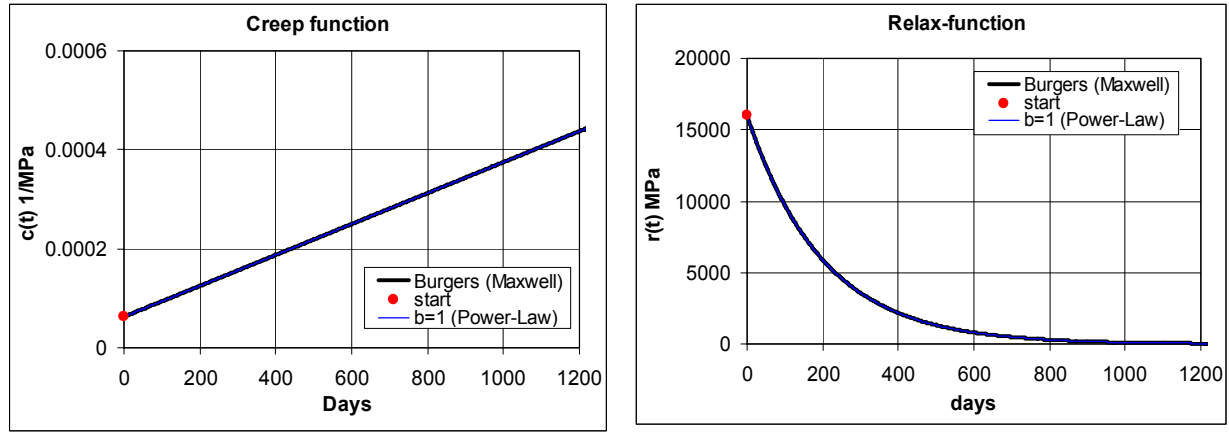

Figure 21. Maxwell material adapted from a Power-Law material with Young's modulus $E_p = 16000$ MPa, relaxation time $\tau_p = 200$ days, and a creep power of $b = 1$. The Maxwell properties become: $E = 16000$ MPa and $\eta = 3.2 \text{ e}6$ MPa*day (corresponding to $\tau = \eta/E = 200$ days).

7. Conclusion and final remarks

Following the procedures explained in Sections 5 and 6 a number of Power-Law expressions, with various parameters E_p , b , τ_p , have successfully been tested with respect to Burgers adaptation. Apparently the process of including a rapid ('invisible') Kelvin strain into elastic (Hooke) strain works well. It is of special interest to notice that the reduced Young's modulus in practice can be predicted by $E = E_p / (1 + (\Delta/\tau_p)^b)$ with $\Delta \approx (1 - b^2)/100$ of the duration of analysis (T).

As previously indicated: Of course, a simplification of a materials viscoelastic stress-strain relation has its price. In the present paper, where Power-Law materials are considered, a maximum loss of accuracy is limited to appear over the first approximately Δ days after stress jumps. The errors, however, will fade out as time proceeds to longer times (within the time, T, decided for the duration of analysis). To illustrate this feature a magnified section of Figure 10 is shown in Figure 22.

As can be seen from Figure 23, errors can be reduced locally, decreasing the duration of analysis (T). This feature might be useful in a higher accuracy analysis for small periods of time.

Nature of errors: We re-call that the errors discussed throughout the paper are not real, permanent errors. They are the results of replacing a fast working Kelvin strain with an extremely fast working Hooke strain. Both such strains are reversible meaning that they, after some time, become equal. In a way these errors are ‘self-repairing’.

Real errors are deviations between Power-Law and Burgers results, which show up after T because the ‘duration of analysis’, T , has been chosen too small, see Figure 24. These errors are of the same kind as those which will turn up if a stress-strain analysis is based on a Burgers model established directly from experimental data collected from tests with too short durations of load, (here 2000 days).

Summary: Viscoelastic analysis (and incremental analysis) of Power-Law materials can be made by stress-strain relations based on the behavior of adapted Burgers creep models. The adaption can be made by a very simple algorithm (Table 4) where the only in-put parameter is the period of analysis (T). The method applies for any creep power $0 < b < 1$, (numerically $0.000000001 \leq b \leq 0.999999999$).

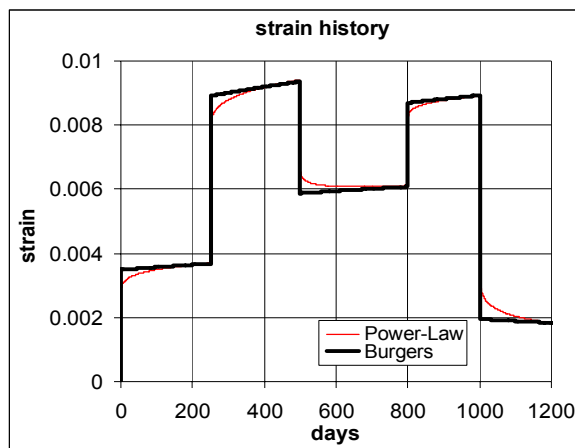

Figure 22. Blow-up of the strain history presented in Figure 10 at ages less than 3 years. (Still from a $T = 30$ years analysis).

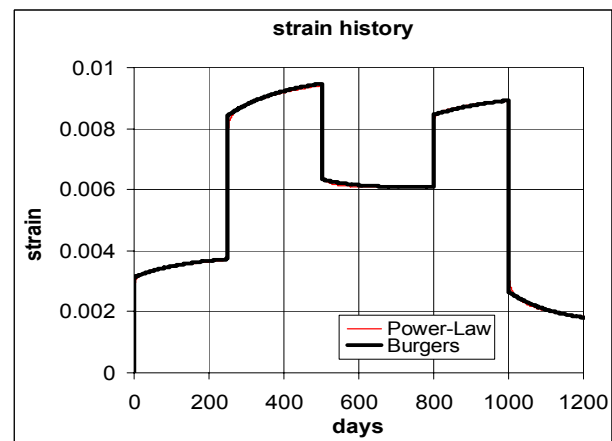

Figure 23. The same example as considered in Figure 10. The duration of analysis, however, is reduced to $T = 1100$ days (3 years).

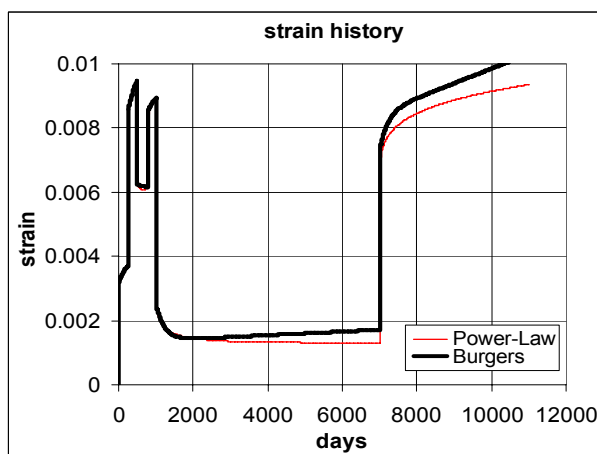

Figure 24. Errors turning up at longer times because the duration of analysis, T , has been chosen too short. In this case $T = 2000$ days. Materials data and load history are as used in example 1, see Figure 10.

The figure is also an illustration of errors, which will turn up if a Burgers model is applied which is based on data collected from tests with too short durations of load (here 2000 days).

Acknowledgement

The author appreciates very much the support he was given from the “Danish Research Agency, project no. 2020-00-0017” to write this paper.

Notations

Subscripts

| | |
|----|----------------|
| K | Kelvin element |
| H | Hooke element |
| N | Newton element |
| P | Power-Law |
| B | Burgers |
| SH | Shrinkage |

Stress-strain

| | |
|--------|---------------|
| Stress | σ |
| Strain | ε |

Various

| | |
|-----------------------|-------------------------------------|
| Moisture content | u (kg/kg dry) |
| Shrinkage coefficient | s (strain pr unit moisture content) |

Creep in general

| | |
|----------------------------|-------------------|
| Time in general | t |
| Creep function | c(t) |
| Relaxation function | r(t) |
| Young's modulus | E |
| Viscosity | η |
| Relaxation time in general | $\theta = \eta/E$ |

Power-Law creep

| | |
|-----------------|----------|
| Relaxation time | τ_p |
| Creep power | b |

Appendix A: On adapted Burgers models

We estimate viscosity from slope of Power-Law at t_{SLOPE}

$$\text{slope} : \alpha = \frac{dc_p}{dt} \Big|_{t_{SLOPE}} = \frac{b}{E_p \tau_p} \left(\frac{t_{SLOPE}}{\tau_p} \right)^{b-1} = \frac{b}{E_p t_{SLOPE}} \left(\frac{t_{SLOPE}}{\tau_p} \right)^b \Rightarrow$$

$$\text{Burgers viscosity } \eta = \frac{1}{\alpha} = \frac{E_p t_{SLOPE}}{b} \left(\frac{t_{SLOPE}}{\tau_p} \right)^{-b}$$

The Burgers Young's moduli are determined as follows:

Calculate the auxiliary parameter Y as follows, see also Figure 8,

$$Y = c_p(t_{SLOPE}) - \alpha t_{SLOPE} = \frac{1}{E_p} \left(1 + (1-b) \left(\frac{t_{SLOPE}}{\tau_p} \right)^b \right) = \frac{1}{E} + \frac{1}{E_K} \text{ where}$$

$E = E_p / \beta$ with $\beta = 1 + (\Delta / \tau_p)^b$ is effective Young's modulus of the Burgers model and

$E_K = \frac{1}{Y - 1/E}$ is effective Young's modulus of the kelvin element

The Kelvin viscosity is calculated as follows assuming coinciding Burgers- and Power creep values at $t = t_{COIN}$:

$$\frac{1}{E_p} \left(1 + \left(\frac{t_{COIN}}{\tau_p} \right)^b \right) = \frac{1}{E} + \frac{t_{COIN}}{\eta} + \frac{1}{E_K} \left(1 - \exp \left(- \frac{t_{COIN} * E_K}{\eta_K} \right) \right) \Rightarrow$$

$$\eta_K = \frac{t_{COIN} * E_K}{-\log_e \left(1 - E_K \left(\frac{1}{E_p} \left(1 + \left(\frac{t_{COIN}}{\tau_p} \right)^b \right) - \frac{1}{E} - \frac{t_{COIN}}{\eta} \right) \right)}$$

Appendix B: On the elastic-viscoelastic analogy

An analogy exists by which solutions to an elastic stress-strain problem can be transformed to solutions applying to the counterpart viscoelastic problem. In a simple form the analogy can be expressed as follows (e.g. 2) where phase P is viscoelastic with creep function, $c_P(t)$, and relaxation function, $r_P(t)$:

1) Viscoelastic solution is obtained from the elastic counterpart solution replacing the flexibility ($1/E$) or the Young's modulus (E) according to

$$\frac{1}{E} \Rightarrow \int_0^t c_P(t-\rho) \frac{d[\]}{d\rho} d\rho \quad \text{or} \quad E \Rightarrow \int_0^t r_P(t-\rho) \frac{d[\]}{d\rho} d\rho \quad \text{respectively}$$

2) An approximate analogy is expressed as follows

| | | | |
|--|---|----------------|--|
| $\left\{ \begin{array}{l} \text{Elastic solution:} \\ \Rightarrow \text{viscoelastic solution:} \end{array} \right.$ | $F_{\text{ELAST}} = F_{\text{ELAST}}(E_P, H)$ $F_{\text{VISC}} \approx F_{\text{ELAST}}(E_P^{\text{EFF}}, H)$ | where | $\left\{ \begin{array}{l} H \text{ is time-dependent action (e.g. load, deform.)} \\ E_P^{\text{EFF}} = \frac{1}{c_P(t)} \text{ is effective Young's modulus} \end{array} \right.$ |
|--|---|----------------|--|

Literature

1. Flügge, W.: "Viscoelasticity", Blaisdell Publ. Comp., London 1967
2. Nielsen, L. Fuglsang: 'Composite Materials - Properties as influenced by Phase Geometry', Springer Verlag, Berlin, Heidelberg 2005.
3. *Idem*: "Power Law Creep as Related to Relaxation, Elasticity, Damping, Rheological Spectra and Creep Recovery - With Special Reference to Wood", Conference of Int. Union of Forestry Research Organizations (IUFRO), Xalapa, Mexico, December 1984. Proceedings, (ed. P. Hoffmeyer) Building Materials Lab., Technical University of Denmark 1985, 181 - 204.
4. Clouser, W.S.: 'Creep of small Wood Beams under constant bending load'. Forest Products Lab., Report 2150, 1959.
5. Nielsen, A.: "Rheology of building materials", thesis, Statens Institut för Byggnadsforskning, Stockholm, Document D6(1972).
6. Nielsen, L. Fuglsang: 'On the influence of moisture and load variations on the strength behavior of wood', presented at the international conference on 'Probabilistic models in timber engineering – tests, models, applications' held in Arcachon, France 8 - 9 September 2005. Proceedings, ARBORA (Association for research on forestry and forest products in Aquitania, France), 2005.
7. *Idem*: 'Models for damage accumulation in wood', 3rd World Conference on Structural Control, 7-12 April 2002 in Como, Italy. Proceedings (Fabio Casciati, editor), Dept. Struct. Mech., University of Pavia, 2002.
8. *Idem*: "Time-dependent behavior of concrete – a basic algorithm for FEM analysis", Byggningsstatistiske Meddelelser, Nr. 3, 1999 (Copenhagen, Denmark).
9. *Idem*: "Kriechen und Relaxations des Betons", Beton- und Stahlbetonbau, 11(1970), 272-275.
10. *Idem*: 'Power-Law creep of wood – composite and dynamic aspects'. IUFRO-Conference on Timber Engineering in Bordeaux, Nancy, France 1992. Proceedings, (ed. P. Hoffmeyer) Building Materials Lab., Technical University of Denmark.